

GENERAL NOTES FOR PARKING DURING CONSTRUCTION OF PHASE 1A

1. Off Street Construction Parking will be available during construction within the east portion of the site.
2. Parking Areas 3 & 4 includes 30 off-street parking spaces for Aurora Housing Authority staff during construction.
3. All drives and walkways are accessible.

4. See Site Plans for Dimensioned Plans
5. During construction there will be 79 parking spaces available for residents who are occupying existing Buildings A, B, C, D, and E as shown in Areas 1, 2, and 3.

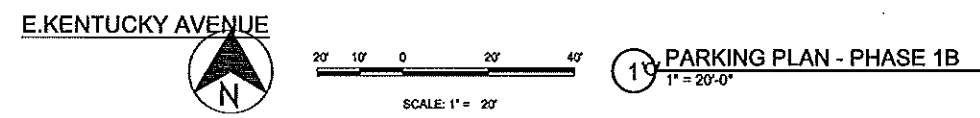

11 PARKING PLAN - PHASE 1B
1" = 20'-0"



2 TYPICAL ACCESSIBLE PARKING SIGNAGE
N.T.S.

SIGNS FOR ACCESSIBLE PARKING SHALL:

1. BE AT LEAST 12 INCHES WIDE AND 18 INCHES HIGH.
2. HAVE WHITE LETTER ON BLUE BACKGROUND.
3. STATE "RESERVED PARKING" AND "TOW AWAY ZONE" ON SUPPLEMENTAL SIGN.
4. SHOW A HANDICAPPED SYMBOL.
5. BE PERMANENTLY MOUNTED WITHIN 10 FEET OF EACH ACCESSIBLE PARKING SPACE.
6. BE LOCATED AT THE CENTER OF THE FRONT OF EACH ACCESSIBLE PARKING SPACE, FACING THE REAR OF THE SPACE.
7. BE 7 FEET ABOVE THE GROUND WHEN MOUNTED ON POST.
8. BE 5 FEET ABOVE THE GROUND WHEN WALL-MOUNTED.

NOTE: SIGNS SHALL CONFORM TO SIGN TYPES R7-8 AND R7-201 OF THE MANUAL ON UNIFORM TRAFFIC CONTROL DEVICES.

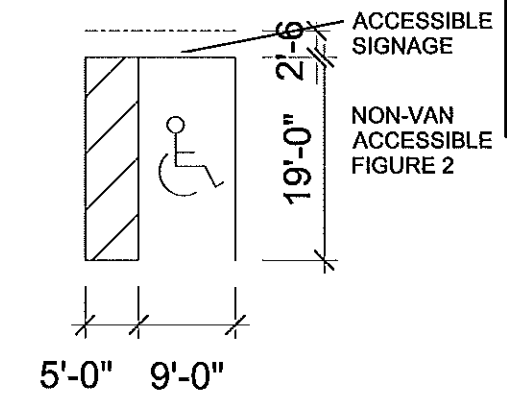
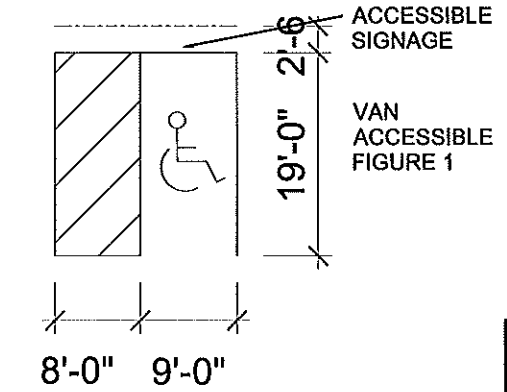

Issue Record		
No.	Description	Date
1	First Submittal	6/5/09
2	Second Submittal	7/31/09
3	Third Submittal	9/8/09
4	Technical Corrections	10/16/09
5	New Phasing	7/23/10
6		



July 23, 2010

PARKING PLAN - PHASE 1B

SHEET 3.2